



HANGCHA GROUP CO., LTD.

Factory site: 666 Xiangfu Road, Hangzhou, Zhejiang, China (311305)

Tel: +86-571-88926735 88926755
Fax: +86-571-88926789 88132890

sales@hcforklift.com
www.hcforklift.com



Follow us on Facebook



Follow us on YouTube



Follow us on WeChat



Download "Hangcha Forklift" App



ISO45001:2018



ISO14001:2015



ISO9001:2015



HANGCHA trucks conform to the European Safety Requirements.

2025 VERSION 8 / COPYRIGHT 2025/11

HANGCHA GROUP CO., LTD. reserves the right to make any changes without notice concerning colors, equipment, or specifications detailed in this brochure, or to discontinue individual models. The colors of trucks, delivered may differ slightly from those in brochures.

XH SERIES HIGH-VOLTAGE LITHIUM BATTERY REACHSTACKER

with capacity of 45,000kg



INNOVATIVE LITHIUM-ION



The World of Hangcha

XH SERIES HIGH-VOLTAGE LITHIUM BATTERY REACHSTACKER

The XH series reachstacker is a newly developed product based on Hangcha's new lithium battery platform of XH series and years of experience in R&D of internal combustion reach stacker. With the new technologies of three-phase drive motor, separate pump control, kinetic energy recovery, etc., the electric reach stacker can make quick operation response at low operation energy consumption. With intelligent and efficient performance, the vehicle is energy-saving, safe and reliable.

THE *Plus*
FOR YOUR
BUSINESS

VOLTAGE

618 V

SPEED MODELS

3 S/P/E mode
(Super/Power/Eco)

CHARGING TIME (20-100%) Max.

2.0 Hour

PROTECTION RATE

IP67

VEHICLE WATER RESISTANCE

IPX4

Exterior

/ With the inherited exterior design of internal combustion reach stackers—pitch-down streamlined design and a smooth, vivid and sturdy profile, the vehicle has smooth coloring, a simple and elegant logo, as well as largely-curved front and rear windows, a large glass ceiling and all-glass side doors to enable a broad view.





FASTER & MORE EFFICIENCY.

Fast charging makes it possible for the whole vehicle to work continuously, shortening the waiting time and greatly improving efficiency.

Through disruptive battery and fast charging technology, the charging time is greatly shortened.



HANGCHA provides CATL Lithium Iron Phosphate (LFP) Battery

HIGH-VOLTAGE

423/560kWh

Max. battery capacity



Maintainability

/ An easy-to-remove hood; all the maintenance points are in easily accessible positions to facilitate repair and maintenance of electrical elements.



Intelligence

- / High-definition LCD instruments have simple graphical interfaces to display data clearly. The interfaces can be switched to be shown in Chinese and English.
- / A vehicle central control system, which has bus architecture, and interconnected motor, battery and heat management control system.
- / Fault diagnosis and alarm functions facilitate maintenance.
- / Display: boom length, actual load, maximum load, boom height, jaw angle, outreach, load percentage bar, alarm code, etc.



Advancement

- / A high-torque permanent magnet synchronous motor provides strong power for the vehicle with performance indicators benchmarked against that of internal combustion forklifts.
- / A 618V high-voltage platform with low system loss and a standard chilled water tank for heavy-duty truck to achieve good heat dissipation.
- / The vehicle has independently developed VCU program along with PDU+MCU+BMS+DC/DC to form a reliable and efficient drive system with flexible function configuration.
- / With motor, electric control and battery adopting liquid-cooling heat dissipation to achieve better heat dissipation, the forklift can absolutely carry out long-time and high-intensity operations.

	Type	Unit	Permanent Magnet Synchronous Motor
Drive motor	Output Power (Peak)	kW	380
	Output Torque (Peak)	N·m	4600

Intelligent Control System

Bus meter control module	Motor control module	Spreader Control Module	Hydraulic Control Module
Lithium battery control module	Thermal Management Control Module	Remote management system	

Functions such as single-joystick operation, spreader's vertical lifting, combined operations, throttle following, etc. make operations more efficient.



Safety

- / The cover of the vehicle is designed to be sealed so that the protection level of the vehicle reaches level IPX4.
- / The electrical system has high-voltage interlocking, insulation protection and monitoring, and potential balancing functions to offer vehicle-grade safety.
- / Both the battery and junction box have MSD(Manual Service Disconnect) maintenance switches to enable one-click power-down and safer maintenance.
- / Key structural parts in reference to internal combustion forklifts have been verified highly reliable by the market for many years.
- / The 6-probe visual reversing radar and wide-view cab offer a wide view without a blind corner.
- / Safety technologies such as seat sensing, dynamic antitipping protection, longitudinal dual anti-tipping protection, spreader twist-lock dual protection, startup anti-stalling protection, fault protection, etc. are used to ensure safe operations at all times.



All the motor, electronic controls and high-voltage components reach the dust and water resistance level of IP67, a high protection level adequate to withstand harsh operating environments and ensure safety and reliability.



The high-voltage lithium battery is equipped with an automatic fire extinguisher for the standard configuration. The vehicle is equipped with a pipe network automatic fire extinguisher for the standard configuration.



Ultra-long battery life

- / Standard large-capacity lithium battery meets long battery life requirements.
- / Both the drive and operating systems are efficient vehicle-grade permanent magnet synchronization systems with low energy consumption.
- / 618V high-voltage platform, less vehicle current and minimal system heat loss
- / Braking energy and potential energy recovery effectively prolongs operating time.
- / A double-gun quick charging port offers a full charge in no more than 2 hours.



CCS2.0 Charging



GB/T Charging



ELME new-generation container spreader



- / For the new-generation ELME817 series telescopic container spreader, the design of the telescopic beam, turntable, etc. are optimized, so that the structural strength is increased, the weight of the spreader is 16% less than that of the spreader of the last generation and the service life is prolonged by 30%.
- / The arrangement of the oil cylinder is changed to be more conducive to maintenance.
- / Design of the hydraulic system is optimized, so that the spreader system has less pressure loss and is more energy-saving and efficient.
- / With electro-hydraulic proportional control, the speed is adjustable and the rotation angle of the spreader can be smoothly and finely controlled.
- / The latest Neuron programmable controller is used so that more optional features can be developed. Fault code information is provided according to the J1939 protocol so that fault query is quick and simple.
- / The twist-lock interlock device (mechanical and electro-hydraulic) and the real-time indication of the action indicator are provided to avoid:
 - the container is lifted when less than 4 corners are locked;
 - the twist-lock is opened when the container is lifted.
- / The lift interrupter can prevent the container from being lifted when the twist-lock is partly twisted. The lift operations can be performed only when the twist-lock is locked or unlocked.

Efficient hydraulic system

- / American PARKER's combined hydraulic valves, PARKER's variable hydraulic pump and the load sensing hydraulic system.
- / Flexible and precise electric proportional control.
- / Light load high-speed lifting increases work efficiency. Independent temperature control and the large-size hydraulic oil cooler meet the work in the environment of up to 50 degrees.
- / Perfect high and low pressure oil filters improve the reliability of the hydraulic system.
- / Multiple hydraulic test points are set to simplify repair and maintenance work.



Fully-suspended all-round vision cab

- / The suspended cabin, easy for maintenance.
- / With the vehicle frame damper connected and the tight sound and heat insulation design, most vibration and noise are shielded.
- / The largely-curved front and rear windows, all-glass left and right doors and large glass ceiling enable a broad view.
- / An inclinable telescopic steering column and fully-suspended adjustable seat with a high backrest and safety belt, with seat sensing and driving position sensing functions
- / A high-power cooling and heating air conditioner, two ventilation modes - internal and external circulation, sunshades, speed-adjustable wipers and defrosting function make driving more comfortable.



Appearance and performance

- / The pitch-down streamlined design of the vehicle presents a vivid and sturdy profile.
- / The optimized counterweight contour greatly reduces the turning radius of the vehicle, broadens the side rear and front rear views, and makes driving simple and safe.
- / The left and right stair handrails, mudguard handrails, together with the anti-skid pedals and anti-skid paper, fully protect the safety of personnel.



Stylish and comfortable

- / **Fashionable and high-end modeling elements**
The pitch-down streamlined design presents a vivid and sturdy profile. Smooth coloring and the simple and elegant logo highlight fashionable and high-end design elements.
- / **Ergonomic control platform**
The ergonomically-designed control platform equipped with reasonably-arranged comfortable-feel buttons enables comfortable and accurate operations, plus the adjustable steering wheel and the suspended seat with an adjustable backrest, making the operator more comfortable.
- / **Quiet, fully-suspended all-round vision cab**
In the cab, noises are less than 78dB and there are a cooling and heating air conditioner, sunshades, a reading light, a radio and other equipment to provide a comfortable operating environment.



Features

Transmission	Standard	Options
Pneumatic tyre	●	
Solid smooth tire		○
Steering system		
Fully hydraulic power steering	●	
Centralized lubrication system (machine)	●	
Automatic Lubrication System		○
Truck		
Tow pin	●	
Electrostatic discharge chain		○
Rear-view mirror on right & left mudguards	●	
Operating system		
Integrated joystick	●	
Adjustable steering column	●	
Adjustable armrest	●	
Hydraulic system		
Variable hydraulic pump system	●	
Operation proportion control	●	
Higher lifting speed at light load	●	
Cab		
Cabin	●	
Climate control system (air-conditioning and heater)	●	
Radio	●	
Sunshade	●	
USB charging interface	●	
Clothes hanger hook	●	
Reading light	●	
1 x 24V power supply		○
1 x 12V power supply		○
License plate frame		○
Fan	●	
Lifting components		
Standard lifting height	●	
Spreader & twistlock double protection	●	
Emergency descent	●	
Twistlock counter	●	
Spreader swing prevention	●	
4 x Spreader twistlock camera		○
2 x Spreader twistlock light	●	
Other		
Standard color	●	
User defined colour		○
Fire extinguisher (2kg/4kg)		○
Vehicle toolkit	●	
Movable Cabin	●	
Overload protection	●	
Lifting height indicator on display	●	
Dynamic speed Limit depending of lift height(customer defined)		○
Automatic throttle control (lift / tilt / spreader)	●	
FIMS(Fleet intelligent management system)	●	

Electrical System	Standard	Options
Operator Presense System (OPS) with buzzer	●	
LCD display screen	●	
Main power switch	●	
Emergency power off switch	●	
Maintenance-free 24V lead acid battery	●	
Reverse buzzer	●	
High decible horn	●	
LED lights (entire vehicle)	●	
4 x Working light on front mudguard	●	
4 x Working light on boom	●	
2 x Rear working light	●	
Reverse sensor	●	
Rearview camera system	●	
Rearview camera system with memory		○
Front & rearview camera system		○
Front & rearview camera system with memory		○
4 directions camera system with single display		○
4 directions camera recording system with single display		○
In cabin CCTV		○
Rear blue safety light		○
Front and rear blue safety light		○
Three sided blue danger zone light		○
Overspeed alarm		○
Speed limitation		○
Voice reverse alarm		○
Automatic fire suppression system	●	
Two-way radio		○
Weight indicator in display	●	
Flashing warning light (non rotating) with control switch	●	
Eccentric load weighing (with printer)		○
Tyre pressure monitoring		○
On-board diagnostics system	●	
Water cooling system for lithium battery	●	
Automatic fire suppression system for lithium battery pack	●	
Manual Service Disconnect (MSD) switch	●	
High voltage interlock	●	
Insulation protection	●	
Power-on self-test	●	
Energy recovery (braking regeneration)	●	
Energy recovery (descent regeneration)	●	
Vehicle Control Unit (VCU)	●	
Dual charging ports	●	
Override switch	●	
central control panel for lighting system	●	
Torque limitation	●	
Vertical lift control		○
Turning deceleration		○
Hour meter	●	
Battery charge indicator	●	
Low hydraulic pressure alarm indicator	●	
Hydraulic oil filter warning indicator	●	
Drive mode indicator	●	
Parking brake indicator	●	
Service indicator	●	

XH Series High-voltage Lithium Battery Reachstacker Specification

Distinguishing mark	1.1	Manufacturer	HANGCHA GROUP CO.,LTD.		
	1.2	Model designation	RS4531CH-XHJG	RS4531CH-XHJG-C	RS4531CH-XHJG-A*
	1.3	Drive: electric (battery or mains), diesel, petrol, fuel gas	Electric	Electric	Electric
	1.4	Operator type: hand, pedestrian, standing, seated, order-picker	Rider seated	Rider seated	Rider seated
	1.5	Rated capacity/rated load(L1,L2,L3)	Q (kg)	45000/31000/16000	45000/31000/16000
	1.6	Load centre,from front face of tyres, row 1	c (mm)	1965	1965
		Load centre,from front face of tyres, row 2	c (mm)	3815	3815
		Load centre,from front face of tyres, row 3	c (mm)	6315	6315
		Stacking capacity,in container row 1-2-3 of 8'6"/9'6"		5/5-5/4-4/3	5/5-5/4-4/3
	1.8	Lost load centre,to front face of tyres	x (mm)	840	840
1.9	Wheelbase	y (mm)	6000	6250	
Weight	2.1	Service Weight	kg	72600	74000
	2.2	Axle load,front at load centre L1,unloaded-loaded	kg	33600/99600	34000/100000
		Axle load,front at load centre L2,unloaded-loaded	kg	34200/93600	34600/94000
	2.3	Axle load,rear at load centre L1,unloaded-loaded	kg	39000/18000	40000/19000
	Axle load,rear at load centre L2,unloaded-loaded	kg	38400/10000	39400/11000	
Wheels & tyres	3.1	Tyres: solid rubber, superelastic, pneumatic, polyurethane		Pneumatic	Pneumatic
	3.2	Tyre size, front		18.00-25-40pr	18.00-25-40pr
	3.3	Tyre size, rear		18.00-25-40pr	18.00-25-40pr
	3.5	Wheels, number front / rear (x = driven wheels)		4x/2	4x/2
	3.6	Tread, front	b10 (mm)	3050	3050
	3.7	Tread, rear	b11 (mm)	2790	2790
Dimensions	4.1	Telescopic boom lift angle,Raised/lowered	$\alpha/\beta(^{\circ})$	60/0	60/0
	4.2	Height telescopic boom lowered	h (mm)	4700	4700
	4.4	Lift (L1,L2,L3)	h2 (mm)	15120/13600/10700	15120/13600/10700
		Seat height relating to SIP	h3 (mm)	2615	2615
	4.15	Twistlock height lowered	h13 (mm)	1280	1280
	4.19	Overall length with boom	l1 (mm)	11625	11875
	4.20	Overall length	l2 (mm)	8123	8371
	4.21	Truck width over drive axle	b1 (mm)	4220	4220
		Spreader sideshift	mm	+/-800(1600)	+/-800(1600)
		Spreader rotation	deg	+105/-195	+105/-195
	4.31	Ground clearance minimum	m1 (mm)	400	400
	4.33	Stacking aisle 20' container	Ast (mm)	11350	11650
	4.34	Stacking aisle 40' container	Ast (mm)	13650	13650
	4.35	Turning radius	Wa (mm)	8100	8300
Performance data	5.1	Travel speed, laden/unladen	km/h	20/22	20/22
	5.2	Lift speed, laden/unladen	m/s	0.25/0.42	0.25/0.42
	5.3	Lowering speed, laden/unladen	m/s	0.36/0.36	0.36/0.36
	5.6	Drawbar pull, laden/unladen	N	230000	230000
	5.8	Gradeability, laden/unladen	%	20/20	20/20
	5.10	Service brake		Wet disc	Wet disc
Electric drivetrain	6.1	Drive motor rating S9 Rated/Peak	kW	214/380	214/380
	6.2	Lift motor rating at S9 Rated/Peak	kW	180/260	180/260
	6.4	Battery Capacity	kWh / Ah	423/684	560/906
		Nominal Voltage	V	618	618
Addition data	10.1	Operating pressure for attachments	MPa	19	19
	10.3	Hydraulic Tank - capacity (drain & refill)	liter	600	600
	10.7	Sound pressure level at the driver 's seat	dB (A)	67	67
	10.8	Towing coupling,type DIN 15170	mm	$\Phi 50$	$\Phi 50$

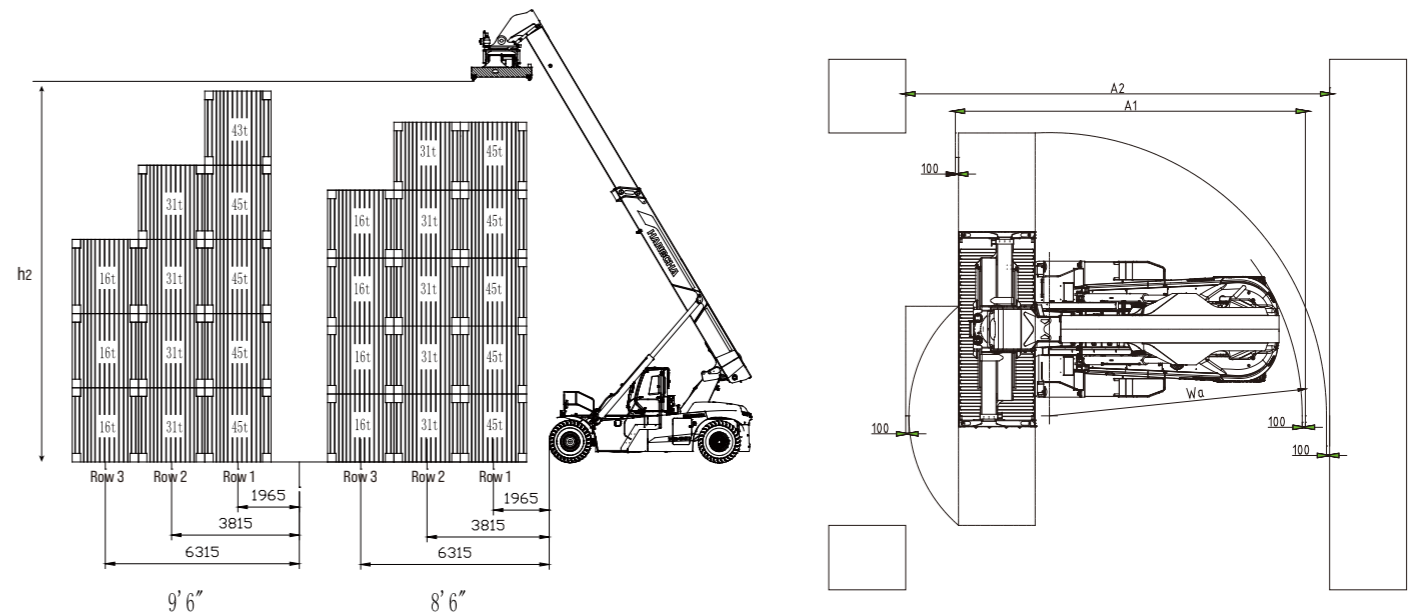
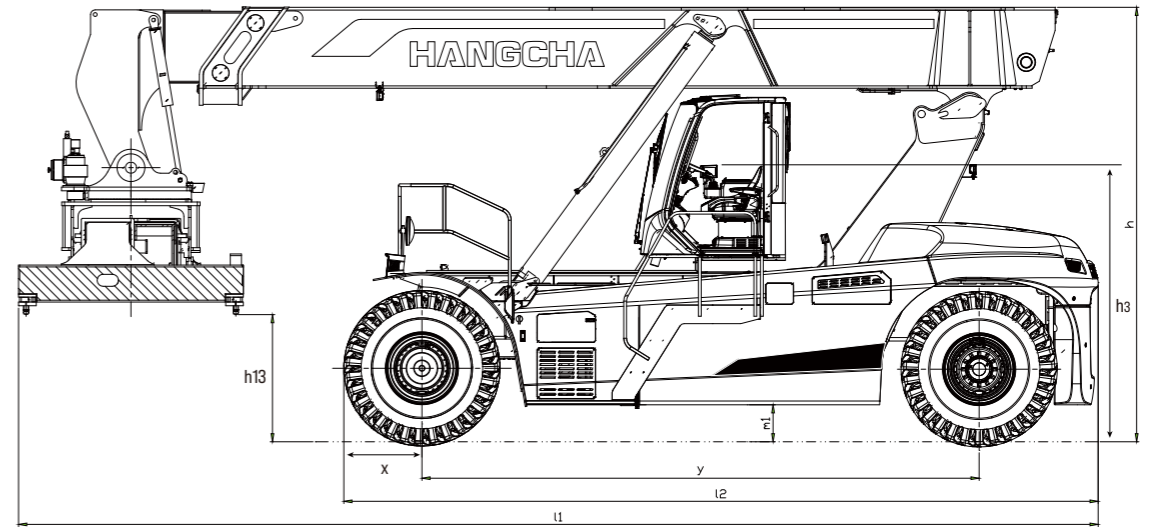
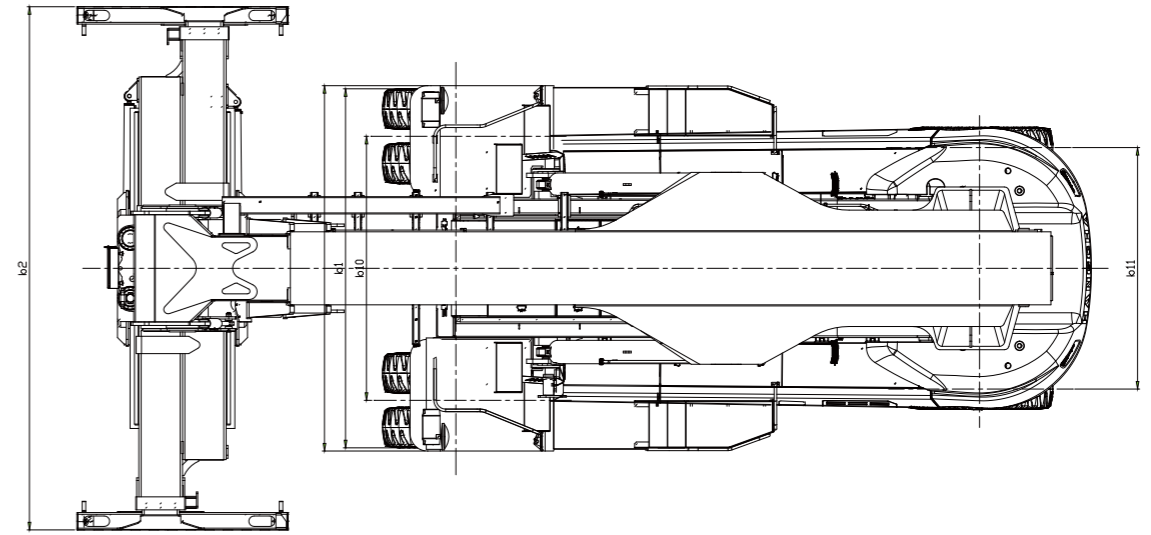

Note: *-A stands for Anti-corrosion Special Model: Equipped with stainless steel bolts, full vehicle anti-corrosion paint, and corrosion-treated electrical connectors.